

Infrared Carbon Dioxide Sensor Module CM1106-Single Beam



Brief introduction

Single Beam (Single light source, single wavelength) NDIR CM1106 (Miniature size) can be used to detect CO₂ concentration of indoor air by adopting advanced non-dispersive infrared technology (NDIR). It is widely used in IAQ monitor, air conditioner with purifying function, air purifier, ventilation system, automotive, agricultural IoT and other consumer electronic products etc.

Main features

- ✧ Advanced non-dispersive infrared technology (NDIR) with independent intellectual property
- ✧ High accuracy: temperature calibration within whole measurement range
- ✧ High stability: advanced auto-calibration at background
- ✧ Small size and compact structure, easy to install

Application

- ✧ Ventilation system
- ✧ Central air-conditioning
- ✧ IAQ monitor
- ✧ Air purifier
- ✧ Plant growth
- ✧ Automotive
- ✧ Indoor CO₂ transmitter

CM1106 Specification List

Measurement range	0-2000ppm,0-5000ppm
Accuracy	±(50ppm+5% of reading),
Response time(T90)	≤ 120S
Temperature influence coefficient	<0.5% FS per°C
Working temperature	-10 °C ~ +50 °C
Humidity	0-95% RH non-condensing
Power supply	DC (5.0±0.1) V, Ripple wave<50mV
Working current	Average 70mA. Peak 170mA
Signal output	PWM: linear output
	UART: TTL (3.3v/5v electrical level)
	I ² C
Size	33*19.7*8.9mm
Lifespan	10 years

Principle of measurement

Molecule like CO₂ and CO is composed of different types of atoms, it has absorption spectrum in infrared range. Absorption intensity abides by Lambert-Beer's Law. When light wave corresponded to certain gas with absorption spectrum passes through measured gas, the intensity of light wave will be significantly weakened. The intensity attenuation is related to concentration of measured gas. This relation follows Lambert-Beer's Law. Basic working principle of NDIR sensor is as below,

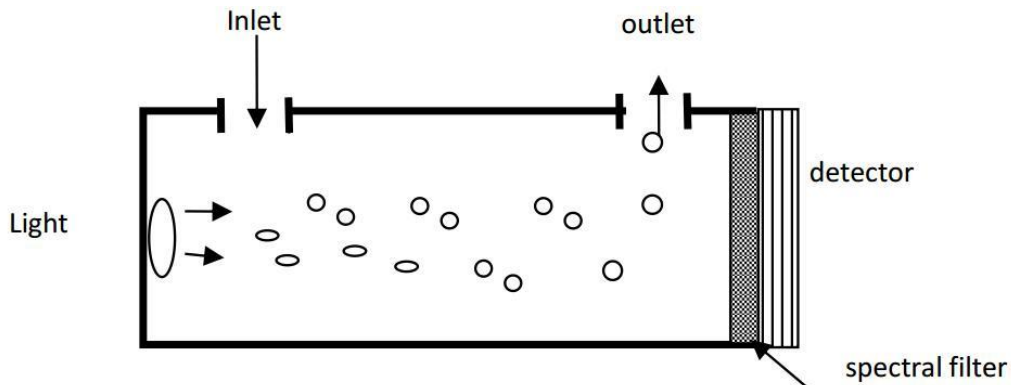

Basic mathematical model: A majority of both organic and inorganic polyatomic gas have specific absorptive wavelength in infrared region. When infrared light passed by, the light transmissivity of this gas molecule to certain wavelength can be expressed by Lambert-Beer Law:

$$I \text{ stands for light transmissivity, } I = I_0 e^{-kpl}$$

$$i \text{ stands for light absorption intensity, } i = I_0 - I = I_0 (1 - e^{-kpl})$$

- I_0** : incident light intensity.
- l** : thickness of gaseous medium
- p** : gas concentration
- k** : absorption coefficient

I/O Definition

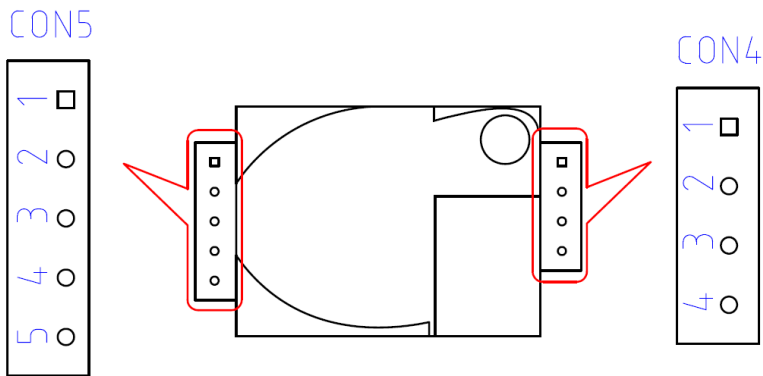

CON5			CON4		
No.	Name	Description	No.	Name	Description
1	+3.3V	Power supply output (+3.3V/100mA)	1	+5V	Power supply input (+5V)
2	RX/SDA	UART-RX (Receiving)/I ² C data, Compatible with 3.3V and 5V communication.	2	GND	Power supply input(GND)
3	TX/SCL	UART-TX (Sending)/ I ² C clock, Compatible with 3.3V and 5V communication.	3	A	Alarming (Reserved)
4	R/T	Output mode exchange: High level or floating is UART communication mode, low level is I ² C communication mode	4	PWM	PWM output
5	CA	Manual calibration			

Description of calibration

Auto calibration:

Rough installing, non-correct soldering and transportation might result in a reducing of sensor reading accuracy and zero drift, sensor will correct the drift by the built-in self-correcting. Powering on the sensor for 7 days continuously, it will record the lowest CO₂ concentration measurement value during these 7 days. Sensor will do auto calibration after 7 days, and will regard the outdoor fresh air CO₂ concentration (400ppm) as baseline. In order to ensure the reading accuracy after auto calibration, please make sure the working environment of sensor can reach the outdoor fresh air level, that is to say, the CO₂ concentration of sensor can reduce to the outdoor air level during the 7 days.

Note: Please contact with Cubic for more detailed auto calibration strategy.

Manual calibration:

Rough installing, non-correct soldering and transportation might result in a reducing of sensor reading accuracy and zero drift. If need to recover accuracy quickly after installing, you can do manual calibration. To put the sensor in the environment where the CO₂ concentration level can reach 400ppm, and to ensure the CO₂ concentration in this environment is stable before calibration. The CA pin of sensor should be well connected at least 2 seconds when doing the manual calibration. Sensor will activate the calibration program after 6 seconds. In addition, sensor also can do manual calibration by sending command, please refer to the communication protocol for more details.

PWM output

Measurement range: 0-2000ppm

PWM cycle : 1004ms

Positive pulse width : (PPM/2) +2ms

PWM output schema :

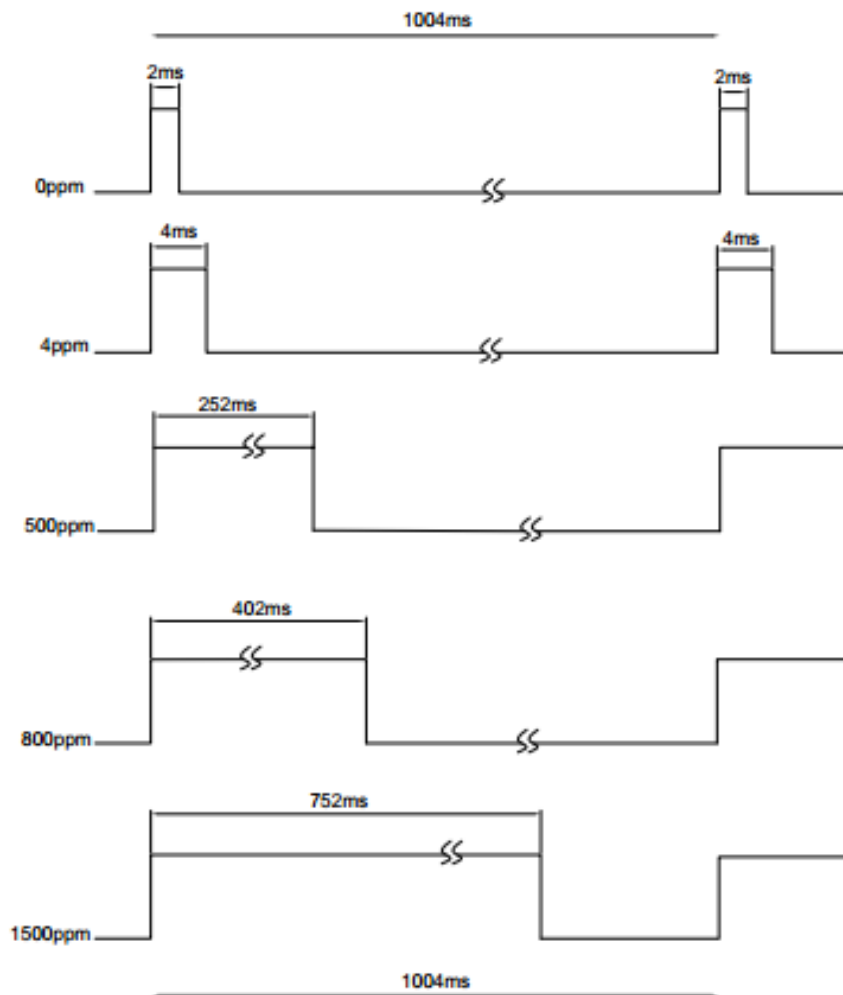

- Connect the pin of PWM to the oscilloscope.
- Add a pull-up resistor around 5K between the pin of PWM and 5V.

Dimensions

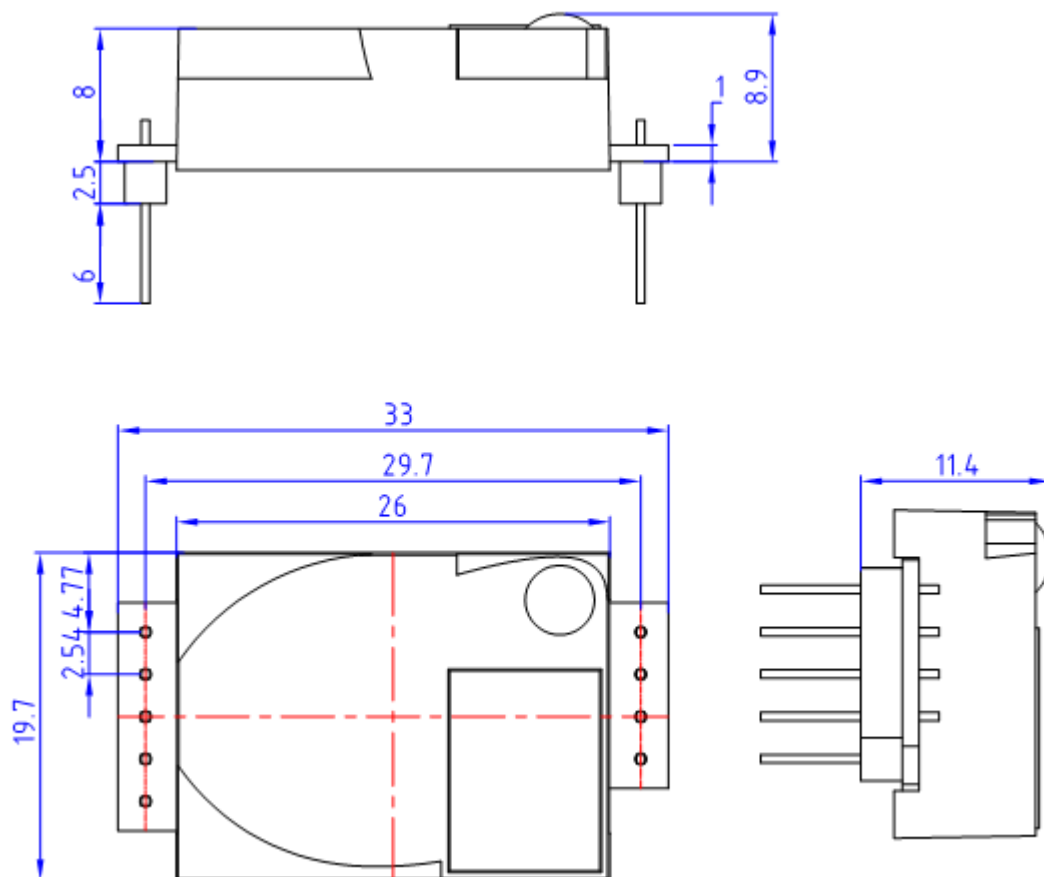

Reliability test

Test List	Test Condition	Standard	Sample qty: N Defective qty: C
Normal temperature	Operating the sensor with power on in the ambient of $25 \pm 2^{\circ}\text{C}$, $(50+10)\%RH$, detecting the measurement error of the sensor in different CO2 concentration.	CO2 stability: $\pm(50+5\%$ of reading) ppm	N=10, C=0
Temperature influence curve	Operating the sensor with power on in the ambient of $-10 \pm 2^{\circ}\text{C}$ 、 $0 \pm 2^{\circ}\text{C}$ 、 $10 \pm 2^{\circ}\text{C}$ 、 $20 \pm 2^{\circ}\text{C}$ 、 $30 \pm 2^{\circ}\text{C}$ 、 $40 \pm 2^{\circ}\text{C}$ 、 $50 \pm 2^{\circ}\text{C}$ separately, detecting the measurement error of the sensor.	The measurement error fits the requirements of the temperature influence curve	
Low temperature working	Operating the sensor powered in the ambient of $-10 \pm 2^{\circ}\text{C}$, detecting the measurement error of the sensor in different CO2 concentration.	The measurement error fits the requirements of the temperature influence curve	N=10, C=0
High temperature working	Operating the sensor with power on in the ambient of $50 \pm 2^{\circ}\text{C}$, detecting the measurement error of the sensor in different CO2 concentration.	The measurement error fits the requirements of the temperature influence curve	
Low humidity operation	Operating the sensor powered in the ambient of $25 \pm 2^{\circ}\text{C}$, $(30 \pm 5)\%RH$, $(50+10)\%RH$, detecting the measurement error of the sensor in different CO2 concentration.	CO2 stability: $\pm(50+5\%$ of reading) ppm	
High humidity operation	Operating the sensor powered in the ambient of $25 \pm 2^{\circ}\text{C}$, $(80 \pm 5)\%RH$, detecting the measurement error of the sensor in different CO2 concentration.	CO2 stability: $\pm(50+5\%$ of reading) ppm	
High temperature storage.	Leave the sensor in the ambient of $60 \pm 2^{\circ}\text{C}$, $(50 \pm 10)\%RH$ for 500 hours without power on, detecting the measurement error of the sensor under normal temperature.	The sensor works normally after 2 hours in the ambient.	N=5, C=0
Low temperature storage.	Leave the sensor in the ambient of $-20 \pm 2^{\circ}\text{C}$ without power on, detecting the measurement error of the sensor under normal temperature.	The sensor works normally after 2 hours in the ambient.	N=5, C=0
Low temperature working	Leave the sensor in the low temperature ambient of $-10 \pm 2^{\circ}\text{C}$, add the highest voltage of the working voltage range. After 500 hours, measuring the error of sensor	The sensor works normally after 2 hours in the ambient.	N=5, C=0

High temperature working	Leave the sensor in the high temperature ambient of $50\pm 2^{\circ}\text{C}$, add the highest voltage of the working voltage range. After 500 hours, measuring the error of sensor	The sensor works normally after 2 hours in the ambient.	N=5, C=0
Thermal cycle	Leave the sensor in ambient of -20°C for 55mins then move it to ambient of $+60^{\circ}\text{C}$ for 55mins. Keep this cycle for 10 times. Samples are powering off during the test.	The sensor works normally after 2 hours in the ambient.	N=5, C=0
High temperature, high humidity working	Leave the sensor in the high temperature, high humidity ambient of $50\pm 2^{\circ}\text{C}$, 80-85%RH, add the highest voltage within voltage working range. Keep for 500 hours.	The sensor works normally after 2 hours in the ambient.	N=5, C=0
Vibration test	10-55-10Hz/min, with amplitude of 1.5mm, vibrate in X,Y,Z direction, each direction for 2 hours.	1) The sensor works normally after 1 hour in the normal temperature. 2) Wire terminals do not fall out.	N=5, C=0
Drop test	Drop the sensor from 70cm height down to the hard wooden board randomly for three times.	Sensor can work normally	N=5, C=0
Salt spray test	According to GB/T2423.17-2008, leave the sensor in the 35°C salt-fog cabinet, spray it with 5% sodium chloride saltwater for 24 hours. Clean the sensor after test.	No red rust on the sensor surface. Rust level: $R_p > 7$	N=5, C=0

Note:

- (1) The definition of normal temperature normal humidity: temperature range: $25\pm 2^{\circ}\text{C}$, humidity range: $50\pm 10\%$ RH.
- (2) The definition of sensor normal working: Sensor can measure normally and output value, but accuracy will be affected.

Ordering information

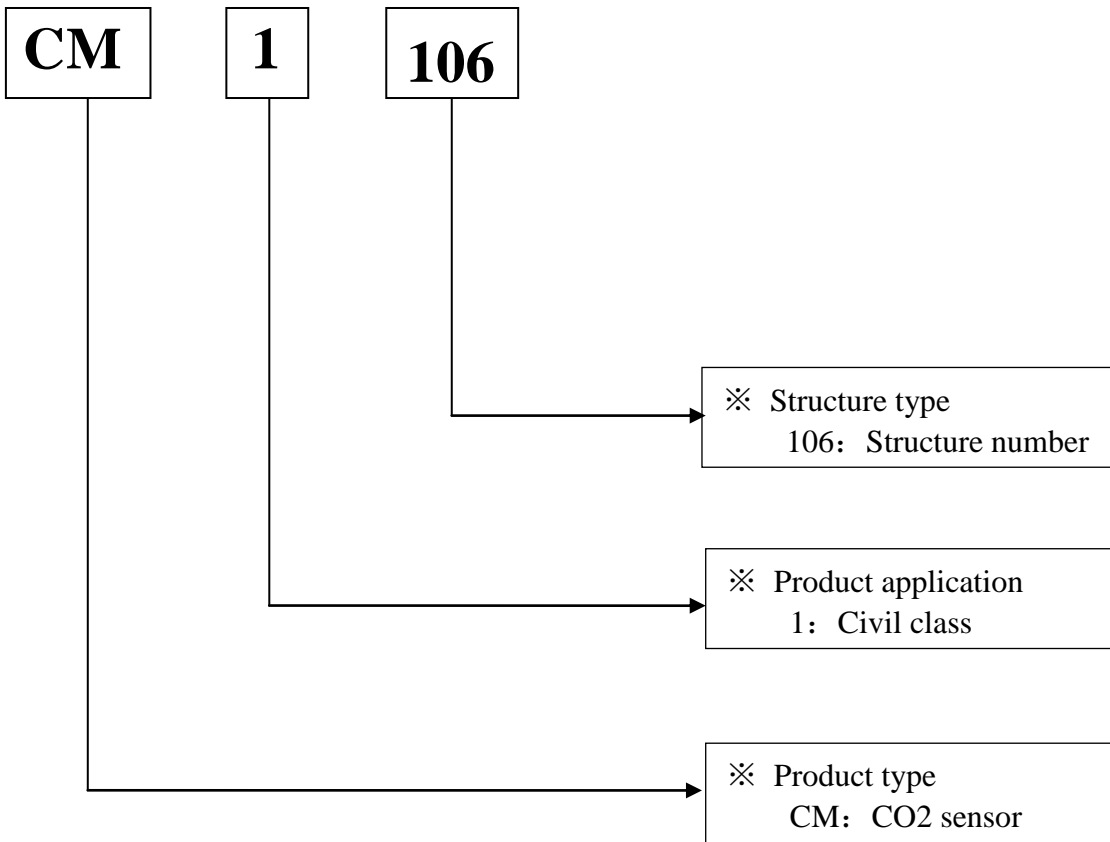

Packing

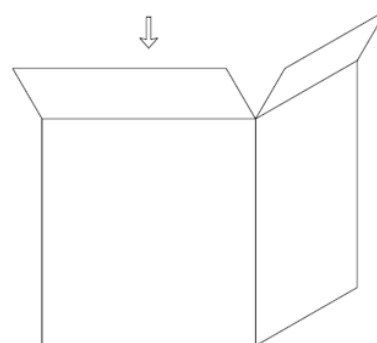
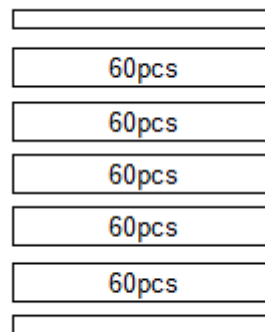
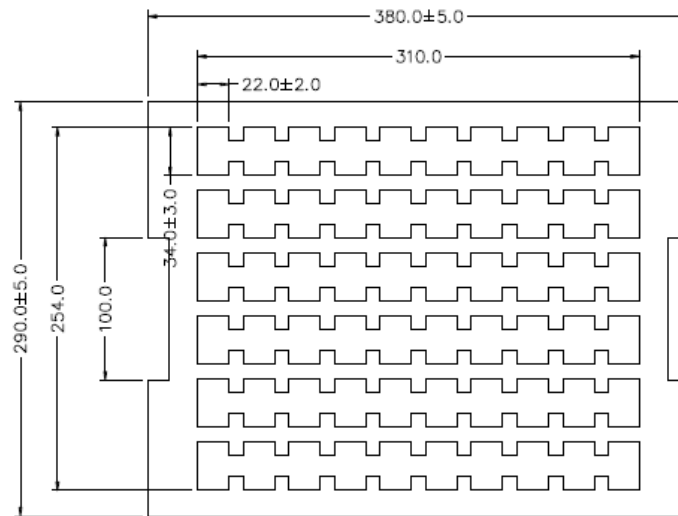

Packing description

Qty per layer	Layer	Carton	Carton dimensions	Packing material
60pcs	18 layers	1080pcs	W400 * L300 * H550 mm	Red pearl cotton (ESD)



After-sales services and consultancy

TEL: 86- 27-81628827 **FAX:** 86-27-81628821

ADD: Fenghuang No.3 Road,Fenghuang Industrial Park, Eastlake Hi-tech Development Zone, Wuhan 430205, China

WEB: www.gassensor.com.cn

E-mail: info@gassensor.com.cn